

KVA VIND 10-10 AND 10-15 WIND TURBINE

USER MANUAL



	Customer Relation Management	Document no.	KVA-A-009-01
		Revision date.	2019.10.21
	User Manual Appendix 1.	Revision no.	1
		Page	2/15

Dear KVA VIND 10-15 Owner,

Thank you for your purchase of a *KVA Vind 10-15* wind turbine.

You have just selected one of the most technologically advanced and cost-effective wind turbines, available for a home or small business. We congratulate you and we hope that you will experience years of reliable service.

Before going any further, please complete and return the enclosed Warranty Registration Card. The conditions of your warranty are depending upon the proper installation of *KVA Vind 10-15*. Furthermore, this will assure you of being kept up-to-date with the latest developments from KVA Wind Int. For your information we want to assure, that we do not sell or distribute your contact information to any third party. We respect your privacy.

If you have any questions or comments, we would like to hear from you.

Please call +45 97 36 41 11 during working hours (Monday-Friday - 7:30 am to 4:00 pm EU Central Time) or send us an email sales@kva-wind.com.

Thank you for investing in the future of wind energy with *KVA Vind 10-15*.

Sincerely,

Kurt Sand Østergaard, CEO
KVA Wind Int. A/S

 <small>DANISH WIND TURBINE TRADITIONS</small>	Customer Relation Management	Document no.	KVA-A-009-01
		Revision date.	2019.10.21
	User Manual Appendix 1.	Revision no.	1
		Page	3/15

Enter model

Model: KVA VIND 10-15



Important security notice

This Instruction Manual contains important operational guidelines and security instructions which require your attention. Before the installation of a *KVA Vind 10-15* it is necessary and important to read this user manual in detail, with special focus on safety matters. During installation and operation, one must refer to this handbook's documentation. If you are unfamiliar with installation as shown below, **DO NOT CONTINUE** and let a qualified Technical Engineer proceed with the correct installation.

Failure to comply with the guidelines and instructions will void your warranty.



Important security notice

DO NOT change anything of the wind turbine parts and **DO NOT** paint the blades. However, if you do so, you lose the right of warranty. Any change can have effect on the behaviour of the wind turbine.

 <small>DANISH WIND TURBINE TRADITIONS</small>	Customer Relation Management	Document no.	KVA-A-009-01
		Revision date.	2019.10.21
	User Manual Appendix 1.	Revision no.	1
		Page	4/15

Index

1. System Description.....	5
2. Overview of <i>KVA Vind 10-15</i>	6
3. Design Basis.....	7
3.1 Blades	9
3.2 Bearings.....	10
3.3 Braking system	10
3.4 Generator	11
3.5 Yawing system.....	12
3.6 Tower	12
4. Electrical installations.....	14
4.1 Voltage controller & inverter for grid connection	14
4.2 KVA Vind 10-15, PLC system	14
5. Troubleshooting	15

 KVA Wind Int. <small>DANISH WIND TURBINE TRADITIONS</small>	Customer Relation Management	Document no.	KVA-A-009-01
		Revision date.	2019.10.21
	User Manual	Revision no.	1
	Appendix 1.	Page	5/15

1. System Description

KVA Vind 10-15 is an upwind turbine. The blades, which are mounted directly on the hub, which is mounted on the alternator driveshaft, are hydraulic pitch regulated. The PLC controller will continuously receive signals from both the rotor and the generator. From these signals, the blade angle is adjusted relative to wind direction and speed. So, the generator constantly delivers an optimal effect. This means that the turbine can run at an aggressive angle at low wind speeds and still control the rotation rate at high speeds. The turbine already begins producing at 2.5 m/s and stops at 25 m/s.

The hydraulic pitch cylinder is located inside of the nacelle. The adjustment of the blades occurs by a piston rod with tapered bearing. The hydraulic pump is mounted at the rear of the nacelle, where the oil for both pitch system and brakes are provided. The blades are mounted on the hub, which is mounted directly on the generator driveshaft.

KVA Vind 10-15 is a direct drive turbine and does not have a gear box. This solution minimizes friction, so all the energy from the blades goes directly into the generator. At the same time, it also minimizes the number of worn parts resulting in very low operating costs.



Figure 1. KVA Vind 10-15 turbine

 <small>DANISH WIND TURBINE TRADITIONS</small>	Customer Relation Management	Document no.	KVA-A-009-01
		Revision date.	2019.10.21
	User Manual	Revision no.	1
	Appendix 1.	Page	6/15

2. Overview of KVA Vind 10-15

In following a summary of the manufacturer and wind turbine configurations.

KVA Vind 10-15 - Data	
Responsible vendor	KVA Wind International A/S Borrisvej 10, Astrup, DK-6900 Skjern, Denmark
Manufacturer	KVA Wind International A/S Borrisvej 10, Astrup, DK-6900 Skjern, Denmark
Model No.	KVA VIND 10-15
Description	Horizontal axis wind turbine with upwind rotor, active blade pitch system, yaw control, permanent magnet generator.
Rated power	15 kW @ 8.5 m/s hub height wind speed
Annual estimated production	43.000 kWh
Rotor diameter	10.5 m
Swept area	86.5 m ²
Number of blades	3
Rotor position	Upwind
Nacelle weight	1000 kg
Blade weight	69 kg (x 3 = 207 kg)
Tower weight	3155 Kg
Protection and shutdown system	Hydraulic steered overspeed protection. Hydraulic braking system. Grid protection settings in controller.
Yaw system	Active yaw control.
Blade pitch control	Hydraulic PLC controlled pitch
Direction of rotation	Clockwise (when viewed from upwind)
Rotor speed	Variable
Cut-in wind speed (V_{in})	2.5 m/s
Cut-out wind speed (V_{out})	25 m/s
IEC wind class	III (V _{ave} = 7.5 m/s)
Generator	Permanent magnet
Maximum output power	18 kW
Maximum output voltage	3 x 400V + N / 50Hz.
Maximum output current	32 A at nominal voltage
Operating temperature range	-30°C to +40°C
Design lifetime	20 years
Relative humidity range	95%
Air density	Nominally 1.225 kg/m ³
Salinity	Near costal
Design rated power	Nominally 10-18 kW
Speed reduction method	Change of pitch angle (PLC system)
Generator speed	Variable
Generator type	18 kW
Turbine controller	PLC system
Grid protection method	Inverter
High speed brake	Electromagnetic brake system
Yaw mechanism	Electrical yaw motor, yaw plate
Blade specification	Fiberglass

Table 1. Overview of KVA Vind 10-15

	Customer Relation Management	Document no.	KVA-A-009-01
		Revision date.	2019.10.21
	User Manual	Revision no.	1
	Appendix 1.	Page	7/15

3. Design Basis

KVA Vind 10-15 nacelle is the housing that protects the main frame and components as shown in Figure 2. – 3 pictures.

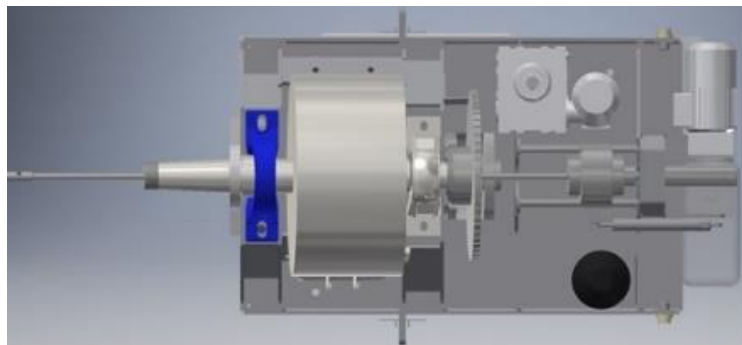
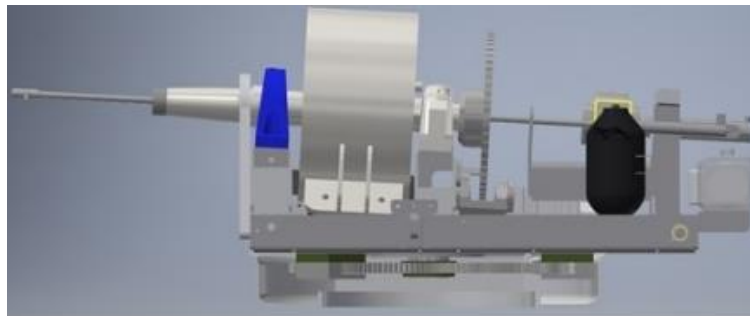
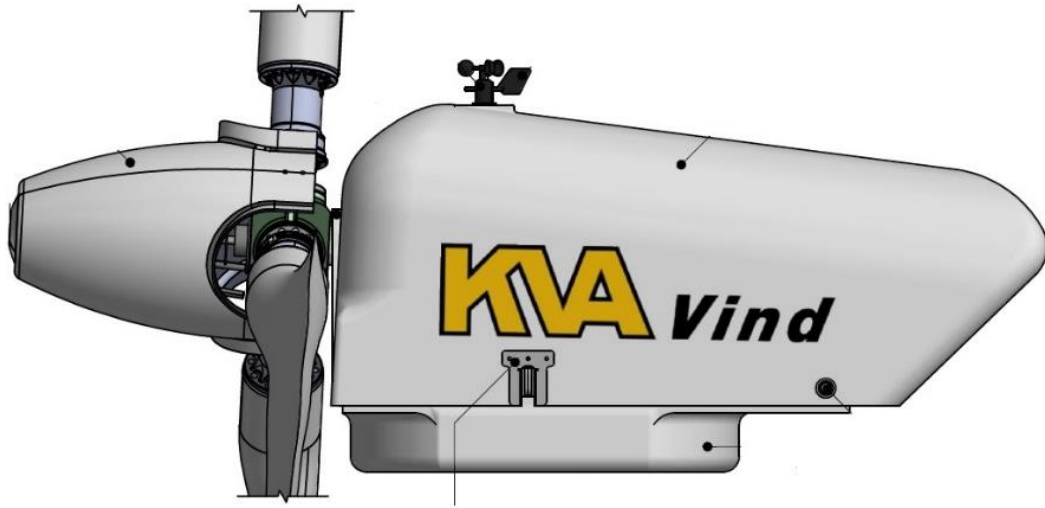

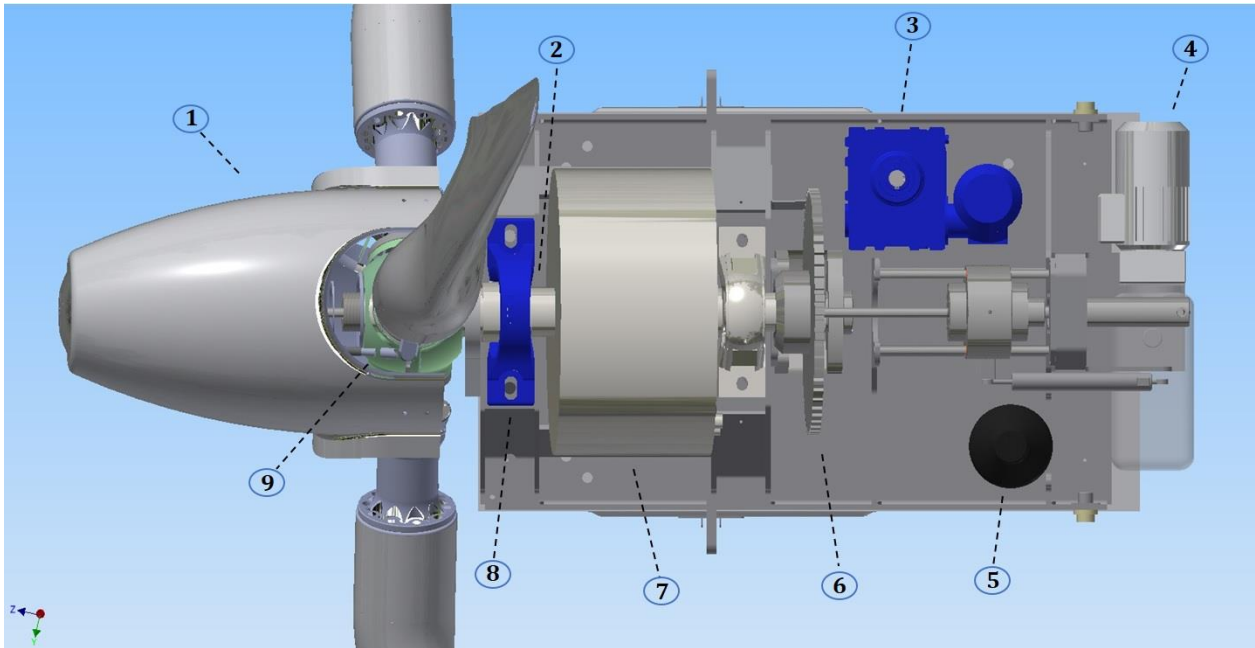



Figure 2. KVA Vind 10-15 components inside the nacelle

 KVA Wind Int. <small>DANISH WIND TURBINE TRADITIONS</small>	Customer Relation Management	Document no.	KVA-A-009-01
	User Manual Appendix 1.	Revision date.	2019.10.21
		Revision no.	1
		Page	8/15



1. Spinner
2. Generator shaft
3. Yaw gear
4. Hydraulic pump
5. Accumulator
6. Brake disc
7. Generator
8. Double bearing support
9. Hub

Figure 3. KVA Vind 10-15 nacelle layout

 KVA Wind Int. <small>DANISH WIND TURBINE TRADITIONS</small>	Customer Relation Management	Document no.	KVA-A-009-01
		Revision date.	2019.10.21
	User Manual Appendix 1.	Revision no.	1
		Page	9/15

3.1 Blades

KVA Vind 10-15 blade is following the Bernoulli aerodynamic principle. The shape of the blade is designed to give a maximum performance. The wind turbine has three fiberglass blades.

The blades are mounted directly on the hub, which is attached to the generator driveshaft. The blades are hydraulic pitch regulated via the PLC controller that continuously receive signals from the generator. The degrees of the blade angle are always adjusted to the wind according these signals, hence the generator constantly delivers an optimal effect.

KVA Vind 10-15 can run at an aggressive angle at low wind speed and still control the rotation rate at high wind speed. The turbine already begins producing at 2.5 m/s and stops at 25 m/s.

KVA Vind 10-15 has a hydraulic pitch system. The hydraulic pitch cylinder is located inside the nacelle, adjusting the blades.

The blade profile is shown in Figure 5.

The blades will automatically pitch out of the wind in case of a power failure. In order to activate pitching on the blades, a spring, which is installed on the rotor in the front of the hub, will start pressing the blades into their stop position.



Figure 5: KVA Vind 10-15 blade profile

 <small>DANISH WIND TURBINE TRADITIONS</small>	Customer Relation Management	Document no.	KVA-A-009-01
		Revision date.	2019.10.21
	User Manual Appendix 1.	Revision no.	1
		Page	10/15

3.2 Bearings

The hub bearings are designed to allow the blade to pitch.

The two main shaft bearings are roller bearing mounted on the main frame.

The bearings are designed to provide bearing and alignment of the generator shaft and accommodate radial and axial loads.

3.3 Braking system

KVA Vind 10-15 has two brake systems.

The turbine can be braked by using the pitch regulation system of the blades. The braking under normal operating conditions is accomplished by pitching the blades out of the wind. In case of the grid connection disappears, the blades will automatically pitch out of the wind. In order to activate pitching on the blades, a spring, which is installed on the rotor in the front of the hub, will start pressing the blades into their stop position.

The hydraulic brake system with a powerful disc brake. The disc brake is connected to a pressure accumulator, guaranteeing that the turbine can be stopped e.g. in case of a power failure or emergency.

 <small>DANISH WIND TURBINE TRADITIONS</small>	Customer Relation Management	Document no.	KVA-A-009-01
		Revision date.	2019.10.21
	User Manual Appendix 1.	Revision no.	1
		Page	11/15

3.4 Generator

The turbine does not have a gearbox. This solution minimizes friction so all the energy from the blades goes directly into the generator.

The generator is designed with specially selected material and treated to resist corrosion and oxidation. It is highly efficient.

The generator is mounted to the bedframe and designed in order to reduce vibration and noise transfer to the bedplate. There is an overview of the generator below.

Please see information below.

Generator	Description
Model	Permanent magnet 18K horizontal
Rotation speed (RPM)	90
Maximum output power (kW)	18
Required torque at nominal power	< 1600 Nm
Weight (kg)	< 440
Phase resistance	0.6 Ohm
Fasteners (nuts and bolts)	High standard stainless steel
Winding temperature rating	180 degree
Magnet material	NdFeB (Neodymium Iron Boron)
Magnet class	SH
Isolation class	F
Magnets temperature rating	150 degree
Generator configuration	3 Phase star connected AC output
Starting torque (NM)	< 6
Phase resistance (ohms)	1.1
Rectified DC current at Rated Output (A)	22,7
Required Torque at rated output (NM)	1600
Output wire square section (mm ²)	10
Lifetime	>20years

Table 2. Description of KVA Vind 10-15, generator

 KVA Wind Int. <small>DANISH WIND TURBINE TRADITIONS</small>	Customer Relation Management	Document no.	KVA-A-009-01
		Revision date.	2019.10.21
	User Manual Appendix 1.	Revision no.	1
		Page	12/15

3.5 Yawing system

The yaw system of KVA Vind 10-15 enables the nacelle to be turned around the tower axis. By turning the front of rotor towards the wind direction it is possible to get an optimal power input. There are three bearings as shown in

3.5.1 Yaw components

Yaw components of KVA Vind 10-15 are yaw brakes and a yaw bearing. The yaw bearing is placed around its outer edge, and the gears of the yaw motors and the yaw brakes are placed on the inside. The yaw mechanism is activated by the PLC controller, which is getting signal from the wind vane, that is measuring the wind position several times per second.

In order to control a stabilized yawing, the yaw bearings have a nylon plate, which is mounted between the tower flange and the yaw bearing.



Figure 4.

The view for installation of yaw system on KVA Vind 10-15

One of the advantages of the bearings is a better stress distribution and therewith a higher lifetime. The main advantage, however, is a reduction of loads on the bedplate and therewith a better bending moment absorption.

3.6 Tower

The tower is 19,5 m high and consists of two parts, a bottom tower and a top tower (bottom: 9730 mm, top: 9980 mm) which are galvanized and mounted on the moulding box. The overview of the tower can be seen Figure 5.

 KVA Wind Int. <small>DANISH WIND TURBINE TRADITIONS</small>	Customer Relation Management	Document no.	KVA-A-009-01
		Revision date.	2019.10.21
	User Manual	Revision no.	1
	Appendix 1.	Page	13/15

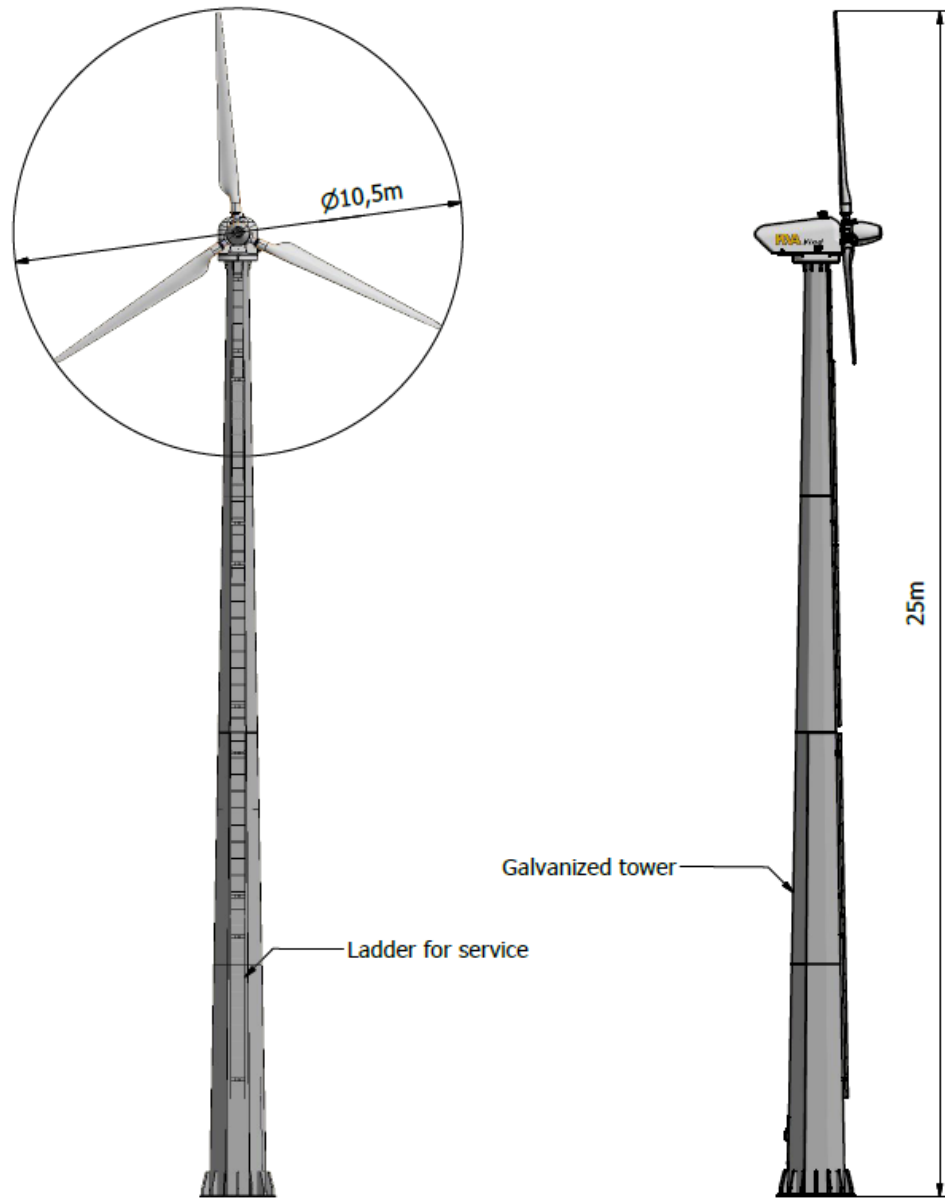



Figure 5 : Overview of KVA Vind 10-15 nacelle, rotor and tower

 <small>DANISH WIND TURBINE TRADITIONS</small>	Customer Relation Management	Document no.	KVA-A-009-01
		Revision date.	2019.10.21
	User Manual	Revision no.	1
	Appendix 1.	Page	14/15

4. Electrical installations

- Transmission lines
- Voltage control
- PLC System

4.1 Voltage controller & inverter for grid connection

Grid connection is one of many options with a KVA Vind 10-15 turbine. In a grid connected KVA Vind 10-15, the system contains a lot of different components like, voltage controller, tablet for monitoring, on/off switch with LED status, automatic brake switch and inverter with power curve programming.

4.2 KVA Vind 10-15, PLC system

The PLC system is controlling and operating the whole turbine. In case of mechanical and electrical failures, a notification is send out to the PLC, which will be shown on the tablet, and will in worst case initiate a shutdown. For the electrical drawing of PLC system, please see *KVA-DK-Q-3.0-Operating & Installation Manual* page 18 and 19.



Figure 6. Front of controller KVA Vind 10-15

 <small>DANISH WIND TURBINE TRADITIONS</small>	Customer Relation Management	Document no.	KVA-A-009-01
		Revision date.	2019.10.21
	User Manual	Revision no.	1
	Appendix 1.	Page	15/15

5. Troubleshooting

Problem	Diagnosis	Solution
The rotor blades run very slowly comparing to the wind speed.	Check generator cable for resistance between phase	Repair cable
Turbine turns too fast.	Check the wire connections, and the power on inverters.	Re-connect to controller, and observe inverter
Turbine is stopped, and there is light in the red button.	Check alarm list on the tablet for further information. Check fuses in the power controller.	Depends on the alarm.
There are no power to the PLC in the power controller.	Check the fuse to the charger, and measure the output power. Check the fuse to the power controller.	If the power for the power controller is gone, check the fuses, or contact a technician
Other problems that are shown in the troubleshoot.	An error that requires technical help is occurred	Call KVA Wind Int. AS: +45 97 36 41 11



If you not are sure about what you are doing, Don't take any risk trying to repair the turbine by yourself. Always contact a technician if you are in doubt!! There is a chance you could break the turbine further or lose your warranty.